

PLANONLIGHT LED

24V machine lamp

Installation instruction

PLEASE READ INSTALLATION INSTRUCTIONS CAREFULLY BEFORE COMMISSIONING!



| | | | | |
|---------------------------------------|---------------------------------------|---------------------------------------|---------------------------------------|---------------------------------------|
| PLANONLIGHT LED 10W Item no. 10290 | PLANONLIGHT LED 20W Item no. 10291 | PLANONLIGHT LED 30W Item no. 10292 | PLANONLIGHT LED 33W Item no. 10293 | PLANONLIGHT LED 66W Item no. 10294 |
|---------------------------------------|---------------------------------------|---------------------------------------|---------------------------------------|---------------------------------------|

TECHNICAL DATA (these are typical values which can deviate in series production)

| Type designation: | L x W x H: | Operating voltage: | Power: | Illuminated area: | Temperature range: | Weight: | Light colour: |
|---------------------|--------------------|--------------------|--------|-------------------|--------------------|---------|-----------------------|
| PLANONLIGHT LED 10W | 241 x 97 x 28 mm* | 24 VDC | 10W | 196 x 57 mm/120° | -20°C to +45°C | 1.20 kg | Bright daylight white |
| PLANONLIGHT LED 20W | 441 x 97 x 28 mm* | 24 VDC | 20W | 396 x 57 mm/120° | -20°C to +45°C | 1.80 kg | Bright daylight white |
| PLANONLIGHT LED 30W | 641 x 97 x 28 mm* | 24 VDC | 30W | 596 x 57 mm/120° | -20°C to +45°C | 2.60 kg | Bright daylight white |
| PLANONLIGHT LED 33W | 421 x 171 x 28 mm* | 24 VDC | 33W | 350 x 109 mm/120° | -20°C to +45°C | 2.90 kg | Bright daylight white |
| PLANONLIGHT LED 66W | 771 x 171 x 28 mm* | 24 VDC | 66W | 700 x 109 mm/120° | -20°C to +45°C | 5.20 kg | Bright daylight white |

*excl. cable gland

FIXING CENTRES WITHOUT LAMP HOLDER (X x Y)

| | |
|---------------------|--------------|
| PLANONLIGHT LED 66W | 750 x 160 mm |
| PLANONLIGHT LED 33W | 400 x 160 mm |
| PLANONLIGHT LED 30W | 620 x 85 mm |
| PLANONLIGHT LED 20W | 420 x 85 mm |
| PLANONLIGHT LED 10W | 220 x 85 mm |

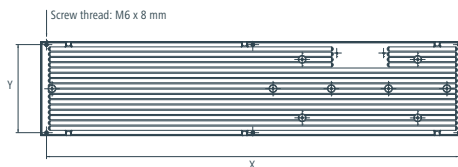

PLANONLIGHT LED DIMENSIONS



LAMP HOLDER DIMENSIONS

Item no. 10404

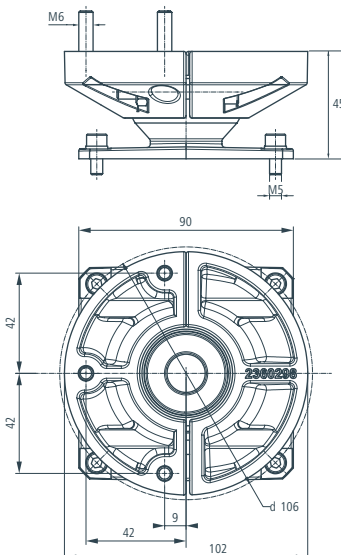

CABLE CONNECTION

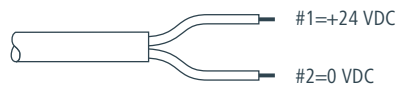

Flexible connection cable:
2 x 1.0 mm² (AWG 16),
L = ca. 2300 mm, Ø = 5.7 +/- 0.4 mm

Direct connection to the mains voltage damages the lamp!

IMPORTANT NOTES

Installation with lamp holders or directly via the four fixing centres.

Keep lamp wire as short as possible.

The cable gland must not be opened (marking with sealing wax).
If the sealing wax is broken, the warranty expires.

The lamp is suitable for direct mounting on normal flammable surfaces.

RoHs compliant, observe WEEE directive for waste electrical and electronic equipment.

All types have the protection class III (SELV), IP protection class IP68 + IP69 K, CE and CB.

Standards: IEC 60598-1, IEC 60598-2-1, UL1598, CSA C22.2 no. 250.0, UL 8750

A detailed installation guide can be found under: www.hagnleone-leuchten.com



PLANON
LIGHT LED

HAGN LEONE GMBH

Bobletten 25, 6850 Dornbirn, Austria
T 0043 (0)5572 39444 - 0
www.hagnleone-leuchten.com